



Electric Winch

Model: CP-300

PN: 150004 220V50Hz 152355 230V50Hz
 153310 100V50Hz 150003 110V60Hz
 150005 115V60Hz

Introduction

► Feature

- Lifting capacity: 300 kg wire rope top layer
- Lifting height: 29 m
- Lifting speed: 10-15 m/min at 50Hz ; 12-18 m/min at 60Hz
- Brake: Electromagnetic spring-applied failsafe brake
- Control: Pendant switch powers the winch

► Unpacking

- Winch assembly..... 1pc
- Wire rope 6 mm x 30 m..... 1pc
- Weight hook CHW-0031..... 1pc
- Power lead 1.5 mm² x 3C x 3 m and plug..... 1pc
- Power lead 3.5mm² x 3C x 0.6m w/o plug for PN:153310.150003.150005..... 1pc
- Pendant switch w/cord 1.25 mm² x 5C x 3 m..... 1pc

► Read this manual carefully

You should carefully read and understand this manual before operating it. Careless winch operation may result in personal injury hazards or property damage.

► Information requesting or parts ordering

Please specify the followings information:

- Winch PN
- Part description
- Replacement part number
- Serial number
- Quantity for each part

Installation

Before using the winch, make sure all electrical components have no corrosion or damaged; the environment should be clear and dry.

► Performance

Winch Model				CP-300							
Motor	kw x p			1.1 x 4							
Recommend Wire Rope	Size(mm)			6							
	Breaking (kg)			2,010							
1 st Layer	Rated Load (kg)	50Hz	444	2 nd Layer	Rated Load (kg)	50Hz	396	3 rd Layer	Rated Load (kg)	50Hz	358
		60Hz	444			60Hz	396			60Hz	358
	Speed (m/min)	50Hz	10	Speed (m/min)	50Hz	11.3	Speed (m/min)	50Hz	12.5		
		60Hz	12			60Hz	13.6			60Hz	15.1
	Rope-Winding Cumulating Sum (m)		5.4		Rope-Winding Cumulating Sum (m)		11.5		Rope-Winding Cumulating Sum (m)		18.3
4 th Layer	Rated Load (kg)	50Hz	327	5 th Layer	Rated Load (kg)	50Hz	300				
		60Hz	327			60Hz	300				
	Speed (m/min)	50Hz	13.8	Speed (m/min)	50Hz	15					
		60Hz	16.5			60Hz	18				
	Rope-Winding Cumulating Sum (m)		25.7		Rope-Winding Cumulating Sum (m)		30				

► Wiring Diagram

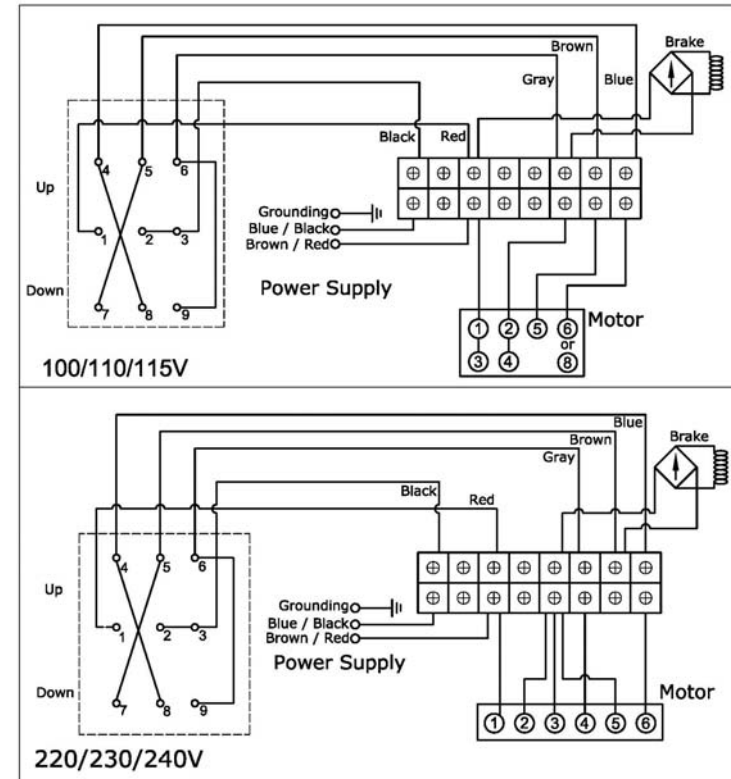

Warning

- The winch is not intended to be used in any manner for the movement or lifting of personnel.
- The lifting capacity shown is based on the top layer of rope on the drum.
- The rope winding on the drum shall remain 5 wraps from the drum.

Parts List

Item No.	Description	Part No.	Qty
1	Induction motor kit , 100/220/50Hz	880413	1
	Induction motor kit , 110V/60Hz	881556	
	Induction motor kit , 230V/50Hz	882542	
	Induction motor kit , 115V/60Hz	881510	
2	Control kit, 3 round pins	880398	1
	Control kit for PN:153310.150003.150005	881329	1
3	Bridge rectifier	880368	1
4	Support bracket	880369	2
5	Drum kit	880370	1
6-1	Tie bar	881862	1
6-2	Tie bar kit	880371	3
7	2 nd shaft kit	880372	1
8	Gear box kit	880373	1
9	1 st stage carrier	880374	1
10	1 st shaft kit	880375	1
11	Conductor kit	880376	1
12	Brake coil 110V	880377	1
13	Conductor plate A	880403	2
14	Brake disc	880379	2
15	Hex socket	880380	1
16	Conductor plate B kit	880381	1
17	Brake cover	880382	1
18	Wire rope	880383	1
19	Weight hook CHW-0031	880384	1

Winch Assembly

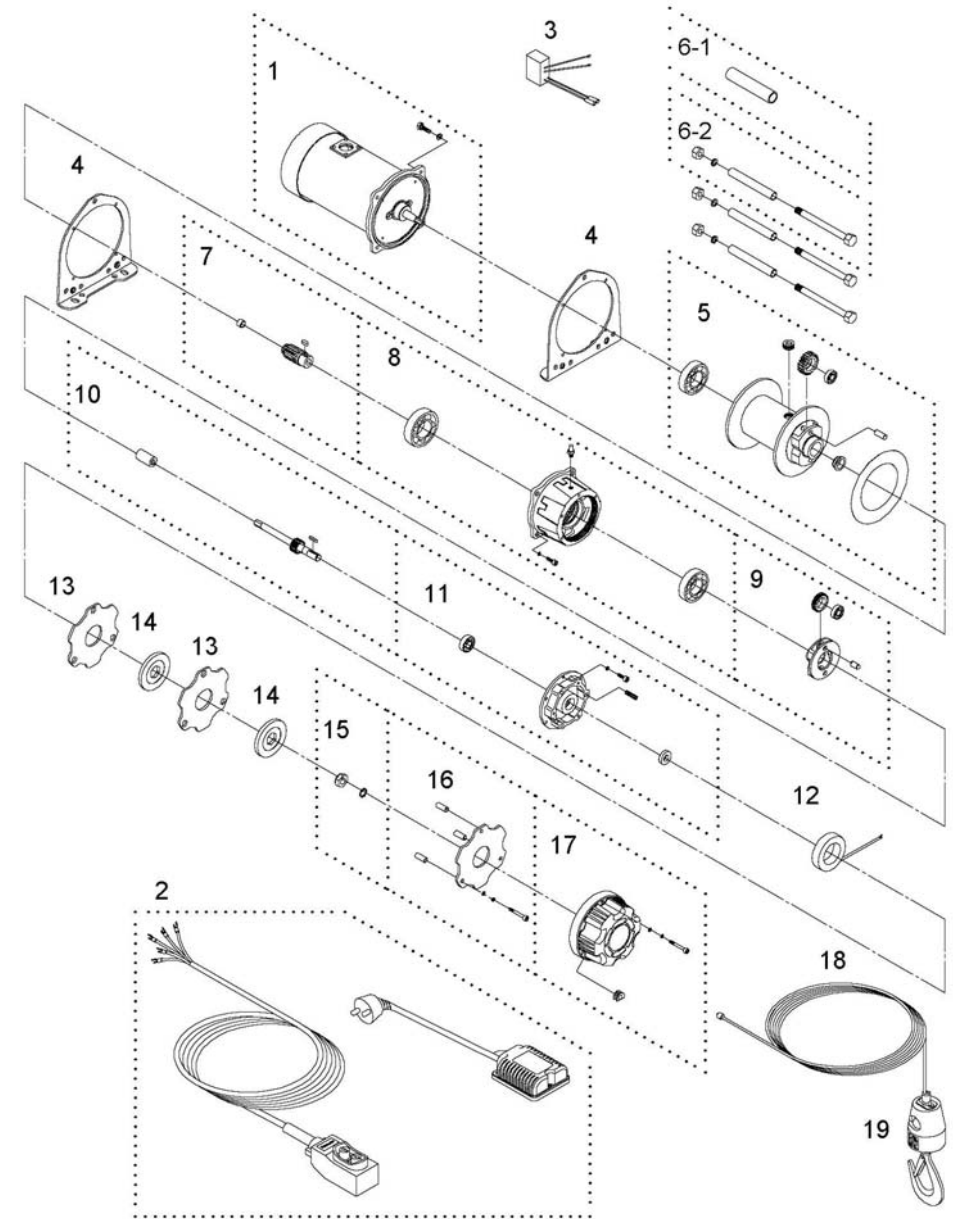

Ver:4